

# CELLULAR NETWORK FOR AUTOMATED IRRIGATION SYSTEM

Nikko Ardel P. Floretes<sup>1</sup>, Francis Jerric J. Candido<sup>2</sup>

<sup>1</sup>*Samar State University, Philippines*

<sup>2</sup>*San Carlos University, Cebu City, Philippines*

[nikko.floretes@ssu.edu.ph](mailto:nikko.floretes@ssu.edu.ph)<sup>1</sup>

[fjc024@yahoo.com](mailto:fjc024@yahoo.com)<sup>2</sup>

## Abstract

The paper proposes a wireless solution, based on GSM (Global System for Mobile Communication) networks for the monitoring of the device, soil humidity and water level of the container in a small scale plantation. This system provides ideal solution for monitoring critical conditions in the plantation. Utilizing soil humidity sensor, water level sensor, water pump, microcontroller, LCD and GSM technology, this system offers a low cost and effective solution to wide range of remote monitoring. The system can configure to transmit data on the status of the plantation, to a mobile phone. Whenever it finishes the water irrigation, the system will send an SMS to the user. The user can monitor the system through his mobile phone by sending commands to GSM modem, and then passed to the microcontroller. The system provides global access to the user since it used GSM as its mobile communication. It has also additional features such as the user can monitor the balance of the load from the system, the user can also control the pump manually or through mobile phone and the system can send the monitoring status via SMS to any number inputted by the user via mobile phone.

**Keywords:** Automation, Drip Irrigation, microcontroller, soil humidity reading, Wireless monitoring

## I. INTRODUCTION

The growing population demands increase in food consumption which will require doubling of food production in developing countries by 2050 (IFC, nd). An efficient irrigation will lead to decreased input use, increased yield and improved crop quality. This will eventually result in environmental sustainability and higher incomes (ibid). A farm with efficient irrigation technologies help small farmers improve their livelihoods by allowing for a more efficient use of inputs, such as water and fertilizer, and by enhancing the yields and quality of the crops, farmers grow (ibid).

Water is essential to living organisms like plants, and for it to survive, it needs water and nutrients which are absorbed by the roots from the soil. Plants are 90 percent water. Roots absorb water from the soil, which is then carried through the plant. Much of the water is taken up through the root hairs, which are tiny rootlets that penetrate the soil around the roots and increase the root's surface area. As the soil dries, the root growth slows. If the soil is saturated with water, the roots could drown (Tangient, 2005).

Knowledge about managing soil and tools like drip irrigation can help poor farmers grow more food today. They can

also discover new approaches and create new tools to fundamentally transform farmers' lives. Agricultural aid fell from 17 percent of all aid from rich countries in 1987 to just 4 percent in 2006. In the past ten years, the demand for food has gone up because of population growth and economic development (Gates, 2012).

In places such as in farms, park and house garden require regular and efficient irrigation of water which is most often done by farmers. Crops or plants are watered or sprinkled with water in unideal time. Watering plants unnecessarily may kill it and at the same time expensive. Pumping water when it is not necessary is an added cost. Most plant just needs enough water; any excess will not be absorbed causing the roots to be flooded with water which may cause the roots to wilt or die.

When the farm is found in remote places will require people to man the watering of plants. A remote monitoring system will be beneficial to the farm owner. The user can monitor his garden anywhere in the country and can access to the system to have the soil humidity reading, water level and pump status. Through SMS coming from the system, therefore, the device is still working and nothing to worry on the irrigation of the plants.

Almost all countries are widely covered with GSM data allowing people to communicate more rapidly. One of its features is sending SMS which can be used as a command prompt to an electronic or computer system. In the past, the maximum number of alphanumeric characters cannot exceed 150 (Gupta, 2004), however today, networks can accommodate up to much higher *number depending on the network*. This is enough to send short alert messages or commands to the remote system. In the world of automation and control, several methods have thus far been employed to attain remote monitoring and control of various processes (Ramamurthy et.al.,

2010). These attempts have met with some problem such as the amount of power usage for transmission of data.

Shinghal, et. al. (2011) found that the most common problems that are involved with humidity sensors (capacitive sensor) used in wireless sensor network node in agricultural applications are generation of a large amount of data to be processed/transmitted. This consumes a large amount of power from a small battery operated by a wireless sensor network node. Another associated problem is corrosion of the connectors due to moisture, extreme/sudden temperature changes, etc.

This study proposes a system that allows the user to monitor and control the system of the plantation ubiquitously and also provide soil humidity reading and status of the pump using GSM technology. It is only a division of wireless sensor network, were it focuses only on the soil humidity measurement. The system does not have storage for the data when there is a power loss.

The primary aim of this paper was to develop the cellular network system for automated irrigation system using the microcontroller PIC18F4550, LCD, localized sensors and a GSM communications module linked by a serial communications port. Using the soil humidity reading could be efficiently recorded from the remote location, and whenever it finishes irrigating the plants, the microprocessor will send an SMS alert to the user's mobile phone regarding the soil humidity, status of the motor and water level. Having these, it concludes that the system is working and it does not have problems.

## II. METHODOLOGY

### 2.1 Project Workflow

This study develops a cellular network for an automated irrigation system as shown in Figure 1. To develop this project, the first

thing to do is analyze the need of the system that can monitor the soil humidity, water pump status and water level to the end users. The contribution of collected data from the internet, electronic books, and other sources can sustain the analysis of the project's system. The study focuses on the primary components; GSM module, soil humidity sensor, water level sensor, PIC microcontroller, water pump motor, and the terrarium for the garden.

After data gathering, we then conceptualize the needed information for the study. After that, the project proceeds in the prototyping process, which includes the interfaces of the circuit like the GSM module to the microcontroller then to the soil humidity and water level sensor and designing the appropriate model of its prototype. Product testing will be done to check whether the desired functions are achieved. If malfunctions occur, then necessary check-up and redesigning of the system is needed to achieve the intended goals for the device.

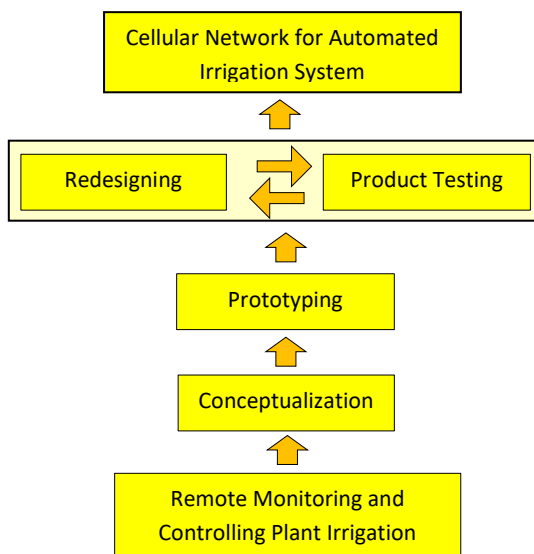

Figure 1. Workflow Diagram

### 2.2 Product Development

The process of the study is that the PIC serves as the brain of the system. If there is a change in the soil humidity data, soil moisture sensors send a signal to the PIC; then it automatically sends the data to the water pump to supply water. The user will retrieve the SMS from the system after the irrigation process with new soil humidity level data. Moreover, having an SMS coming from the system tells that the system is still operating. The operation of the system plays an important role of the study, especially that the system is located in a distant place. Maintenance of the system must be checked properly. The user can also control the water pump for irrigation of the plants via SMS, to have a full usage of the GSM. Malfunctioning of the device can cause the irrigation process to stop. The user just needs to send a message to the system to get the status of the soil humidity reading, water level and the motor operation of the system. The LEDs, serve as the indicators that the system is working and determining soil humidity level. Additional features, such as it can have load balance of the system, can change the receiver of the SMS coming from the system, and manual operation of irrigation.

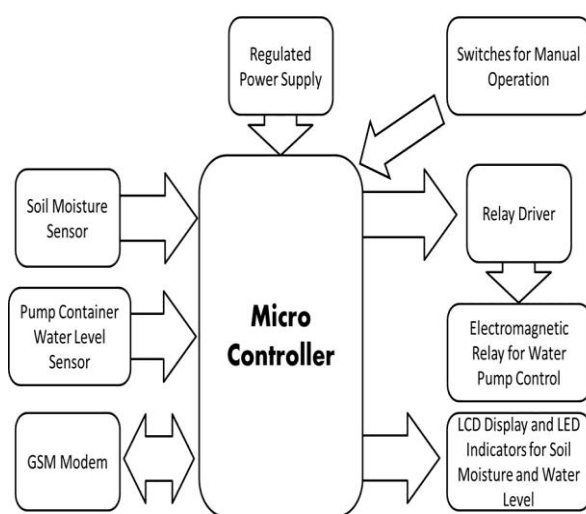

Figure 2. System Block Diagram

The PIC microcontroller serves as the brain for the whole system; it is the controller

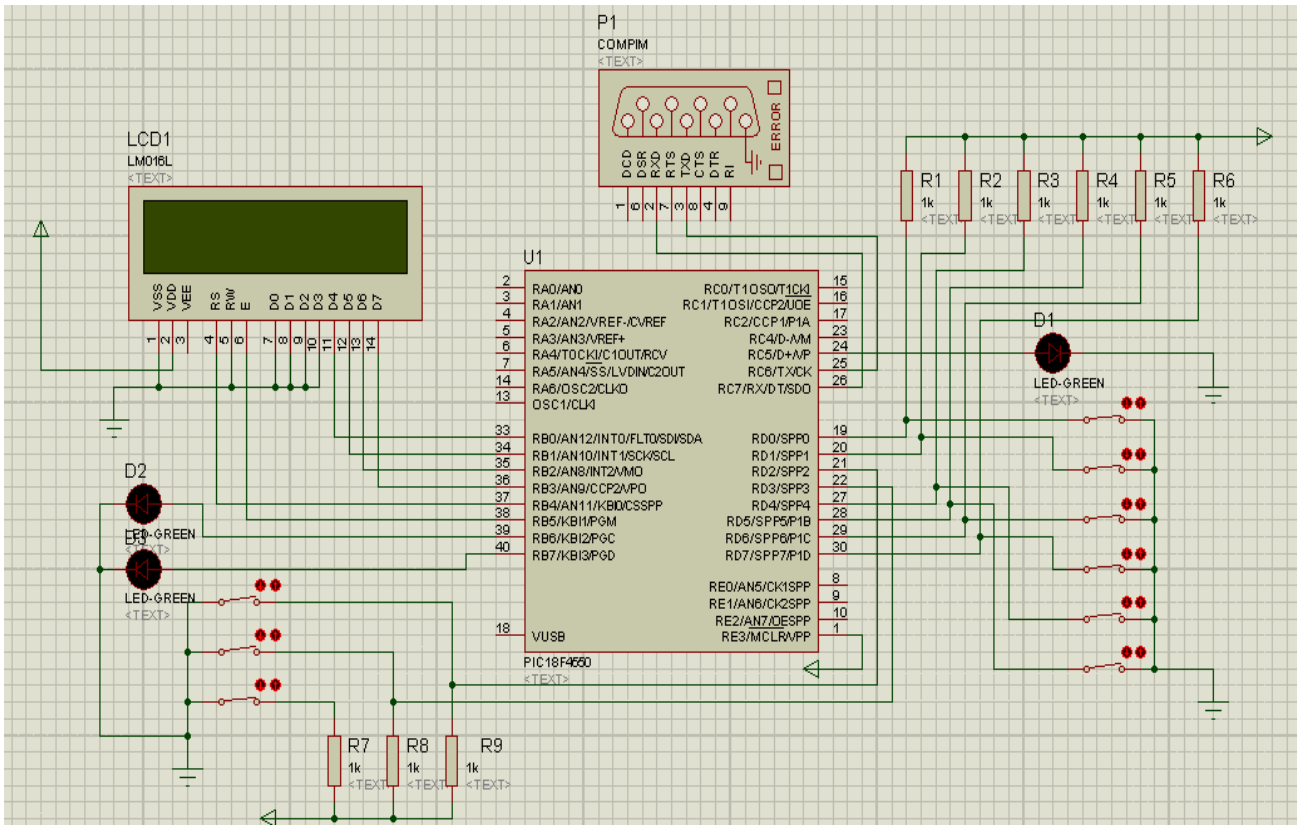

Fig. 3. Project Schematic Diagram

for all peripherals connected to it. For the simulation, the researchers used hyper terminal serial port for the GSM module. The six switches served as the soil humidity sensors; the other three switches served as the water level sensor. A button for the manual operation of the pump. And an LCD, for the visual presentation of data.

### 2.3 System Component

**Sensors.** The sensor used is LM 324. A probe containing two electrodes is used as humidity detector and water level indicator. The operation of the sensor is done by outputting 5V to the PIC. If the two connectors are open. And, an output of 0v if it is short circuited.

**Control Unit.** PIC microcontroller manufactured by Microchip was used as the control unit of the system. The function of the control unit was used as an interface between the sensors, GSM modem and the

control of the motor pump. It received the calibrated humidity data in the form of voltage, manipulated them and sent the data to the user's mobile phone through GSM modem. The selected PIC microcontroller is PIC18F4550.

**Terrarium.** The terrarium consists of six plots each having the same amount of soil. It has the hole in the middle that serves as the passage for the excess of water and, a hose for the irrigation of the water.

**Wireless Module.** GSM (Global System for Mobile Communications) was used to transmit data of soil humidity, water level and motor status including other function. This module also receives commands from the registered user through SMS commands.

**Water motor.** The water pump irrigates the field through a pipe system. It is switched on via a command from the PIC or

through an SMS command from the registered system user. The same is shut off when the desired water moisture is detected by the PIC or forced stopped through an SMS command by the registered user.

2.4 Product Evaluation

The system was tested according to the functions it was designed for. For 20 test runs, each function was checked and compared to how it was designed. The frequency of successful operation was recorded. The system was designed to automatically switch the pumps when the soil moisture goes below the limit and stops when the desired water moisture was

attained. The system was also designed to monitor set-up conditions (i.e. soil moisture status, pump status, water level, loads balance) or switch on/off the pumps through GSM text. Data was presented in frequency counts and percentages.

III. RESULTS AND DISCUSSIONS

*The Automated Irrigation System.* The prototype system is composed of a (a) terrarium/the prototype farm divided into eight plots; a water tank (b) with a pump(c); the automation system (d) where the microcontroller and the GSM modules are housed; the water distribution system (e);

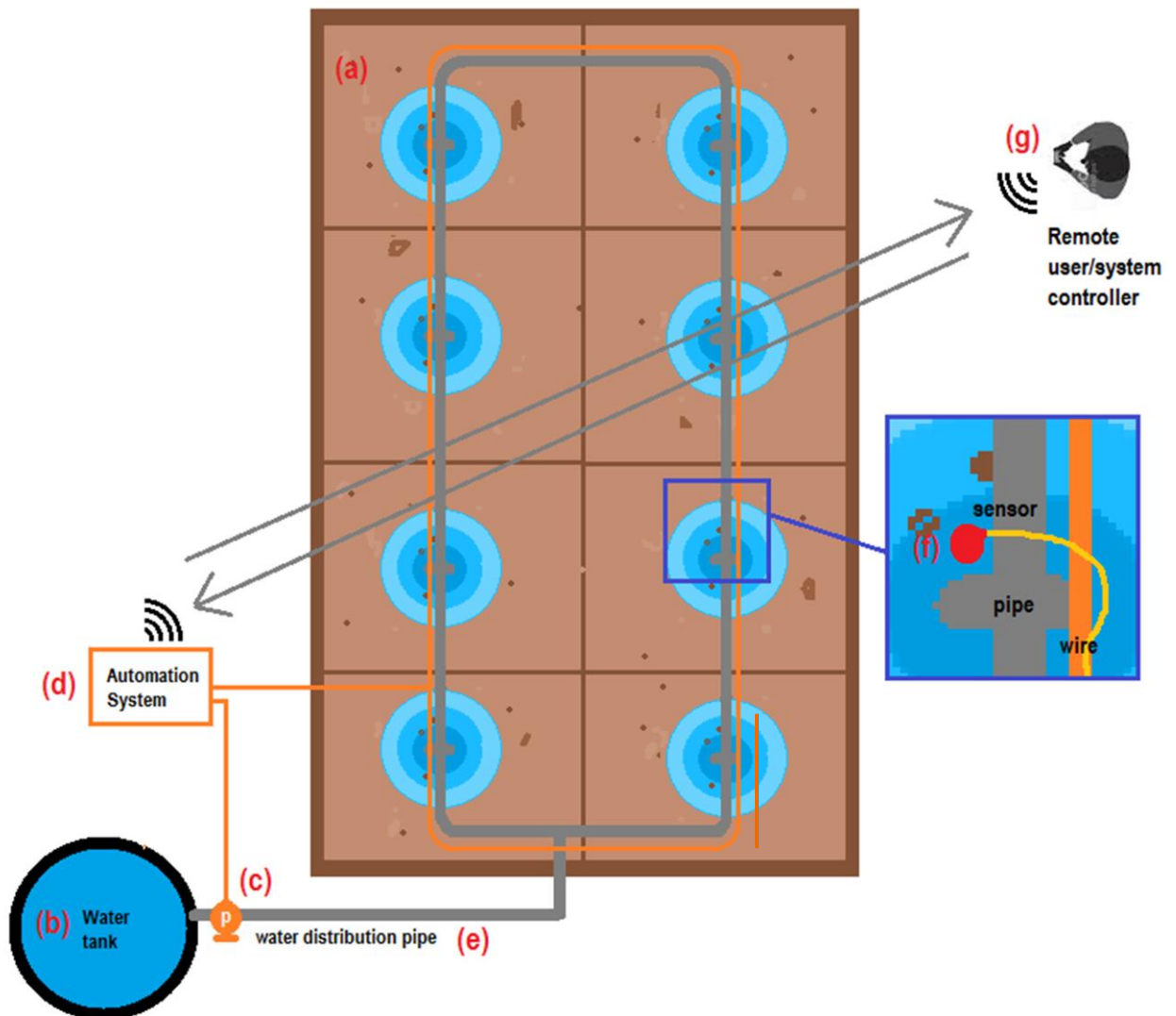

Figure 4. The Automated Irrigation System

the sensor system (f) and the external user/remote user (g). The microcontroller acts as the brain of the system. It detects the moisture level of the soil in every plot, and once the lower-level threshold was detected, it switches the pump to irrigate the plots. When the sensor detected that the upper threshold of soil moisture was achieved, the system switches off the pump. The water level in the pump is also regularly monitored by the system and pump is also switched on to fill the tank when the critical level is detected. The system can also be overridden by the registered user. The registered user is also regularly notified according to the status of the pump, the soil moisture and the load status of the mobile account.

*System Functionality.* The product was tested for 20 trials or attempts to determine if the automated system works. There were eight functionality tests performed as shown in Table 1. Sending the SMS from the System, Receiving the SMS from the User, Water Pump Status, Soil Humidity and Water Level Reading, Changing the User Number, Load Balance, and Manual Mode. Results showed that the system is acceptable for its functions.

After almost seven revisions, the system functions were 100% realized.

Factors identified that lead to the lower success rate in the first evaluation were due to the program malfunction, microcontroller's special features that were not initialized properly, and hardware malfunctions. It was also found out that soil moisture was very variable in the entire field which was attributed to sensor distance and soil properties.

*Soil Moisture Accuracy.* Of the entire system, the sensors detecting moisture of soil was limited where the sensor is found. This means that for every plot, several sensors needs to be installed to accurately detect the soil moisture. This will make the system expensive and difficult to maintain. As shown in figure 5, the sensor can detect 95 to 100% moisture correctly up to 20 cm from the sensor. Accuracy level changes depending on the location of the test sample. The said accuracy is also dependent on the soil permeability or the property of soil to transmit water.

The wired sensor may not be ideal in a large farm set-up. It will be costly and maintenance will also be an issue. This can be resolved through a localized sensor set-up that is also wireless. A wireless soil moisture monitoring will have lower maintenance cost but maybe more costly.

Table 1. System Functionality Test

Functions	First Evaluation		Second Evaluation (After enhancement)	
	Success	%	Success	%
Sending SMS from the system	18	90.0	20	100.0
Receiving SMS from the user	17	85.0	20	100.0
Water Pump Status	15	75.0	20	100.0
Soil humidity reading	14	70.0	20	100.0
Water level reading	17	85.0	20	100.0
Changing the user number	14	70.0	20	100.0
Load balance	14	70.0	20	100.0
Manual mode	19	95.0	20	100.0

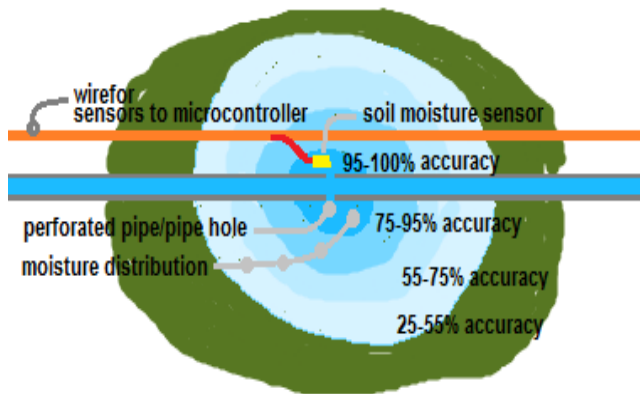

Figure 5. Soil moisture distribution (top view)

**Pump Operation.** The pump is triggered to operate in two ways. One through a command via SMS made by the system owner or one who has access to the system while the other is triggered by the level of moisture of the soil. The later mode of switching off and on has issues relative again to the moisture level of the soil. Since there are several sensors (one for every plot in this prototype project), one plot with detected low moisture (as set by the system owner) will trigger the pump to be switched on to water the plot. However, the system has only one pump and one piping system, causing other plots to have very high moisture. This scenario (depending on the plants) will cause drowning of the plants. This was managed by programming the system to get the average soil moisture of every plot as the basis for switching on and off of the pump.

#### IV. CONCLUSIONS

Automating a farm system is proven to be doable in this prototype. The system is capable of switching on and off automatically of the water pump to supply water to the field when the average water moisture in the plots is detected. The registered user anywhere can access the status of the system (the plot moisture, the water tank level, the status of the pump the load of the GSM, etc.). The

user can also override the system for manual switching on and off of the pump to water the plants or fill-in the tank.

A stand alone wireless sensor system installed on the field will be more appropriate for large farms. Also, instead of water distribution pump installed below or on the ground, a sprinkler system above the ground may also be used.

To minimize cost on GSM operation, a wireless system not using GSM maybe explored.

#### REFERENCES

- Ariff, M. H. & Ibrahim, M. Z. (2010). Solar Powered Soil Moisture Detector. Latest Trends On Communications And Information Technology, 79-83. <http://www.wseas.us/e-library/conferences/2010/Corfu/CIT/CI-T-13.pdf> Accessed 12/12/14
- Awati, J. S., & Patil, V. S. (2012). Automatic Irrigation Control By Using Wireless Sensor Networks. Journal of Exclusive Management Science - June 2012-Vol 1 Issue 6. Retrieved from <http://jems.net.in/Automatic%20irrigation%20control%20by%20using%20wireless%20sensor%20networks.pdf> Accessed 1/13/15
- Bhaltadak, N. S., Ingale, H. T., & Chaudhari, S. K. (2015). GSM based Remote Sensing and Control of an Irrigation System using WSN: a Survey. International Journal of Innovative Research in Science, Engineering and Technology (An ISO 3297: 2007 Certified Organization) Vol. 4, Issue 6, 4268-4273. doi: 10.15680/IJIRSET.2015.0406096
- Gates, B. (2012). Annual Letter from Bill Gates. <http://www.gatesfoundation.org/Who-We-Are/Resources-and->

[Media/Annual-Letters-List/Annual-Letter-2012](#) Accessed 11/19/14

- Gautam, I., & Reddy, S. R. N. (2012). Innovative GSM Bluetooth Based Remote Controlled Embedded System for Irrigation. International Journal of Computer Applications, Volume 47, No. 13, 1-7. doi: 10.5120/7245-0043
- Gupta, P. (2004). SMS: How, what and where, WDN. <http://www.wirelessdevnet.com/channels/sms/features/sms.html> Accessed 3/2/15
- Hade, A. H., & Sengupta, M. K. (2014). Automatic Control of Drip Irrigation System & Monitoring Of Soil by Wireless. IOSR Journal of Agriculture and Veterinary Science (IOSR-JAVS) Volume 7, Issue 4 Ver. III, 57-61. <http://www.iosrjournals.org/iosr-javs/papers/vol7-issue4/Version-3/J07435761.pdf> Accessed 3/22/15
- Hussain, R., Sahgal, J. L., & Anshulgangwar, M. R. (2013). Control of Irrigation Automatically By Using Wireless Sensor Network. International Journal of Soft Computing and Engineering (IJSCE), Vol. 3, Issue-1, 324-328. <http://www.ijsce.org/attachments/File/v3i1/A1390033113.pdf> Accessed 3/08/15
- International Finance Commission (IFC) – World Bank (n.d.). Impact of Efficient Irrigation Technology on Small Farmers. <https://www.ifc.org/wps/wcm/connect/2a54040046a86bc6989db99916182e35/Impact+of+Efficient+Irrigation+Technology+on+Small+Farmers+-+IFC+Brochure.pdf?MOD=AJPERES> Accessed: 5/2//2015
- Ramamurthy B, Bhargavi & ShashiKumar R. (2010). Development of a Low-Cost GSM SMS-Based Humidity Remote Monitoring and Control system for Industrial Applications. International Journal of Advanced Computer Science and Applications. 1(4)
- Shinghal, K., Noor, A., Srivastava, N., & Singh, R. (2011). Intelligent Humidity Sensor For Wireless Sensor Network Agricultural Application. International Journal of Wireless & Mobile Networks (IJWMN) Vol. 3, No. 1, 118-128. doi: 10.5121/ijwmn.2011.3111
- Surani, M. B. (2009). Soil Humidity Monitoring System. Thesis, Universiti Teknologi Malaysia. Retrieved from [http://portal.fke.utm.my/libraryfke/files/381\\_MOHDAZALIBINSURANI2009.pdf](http://portal.fke.utm.my/libraryfke/files/381_MOHDAZALIBINSURANI2009.pdf) Accessed 11/17/14
- Tangent, L. L. C. (2005). The Importance of Water to Plants. <http://iat-engineering-students.wikispaces.com/Plant+water> Accessed 02/27/15